

# Application Bulletin

Of interest to: General

H 1

## Platinization of platinum electrodes and conductivity measuring cells

### Principle

It is a comparatively easy matter to coat platinum electrodes with platinum black by electrolytic deposition of the metal from a platinizing solution.

### Circuit:

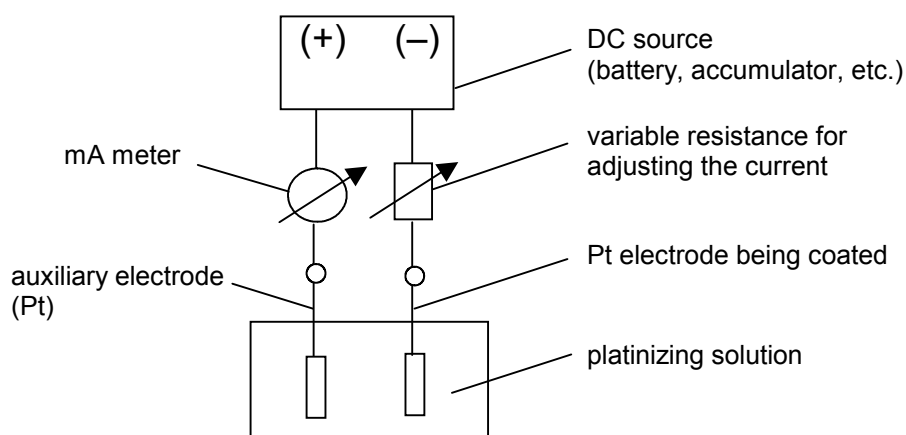

### Reagents

#### Platinizing solution (according to Lummer-Kurlbaum):

Dissolve 3 g chloroplatinic(IV) acid hexahydrate  $\text{H}_2[\text{PtCl}_6] \times 6 \text{H}_2\text{O}$  and 30 mg lead acetate in 100 mL distilled water.

### Pre-treatment

Before use, degrease the new platinum electrode and etch it for a few minutes in hot aqua regia (50 °C) (3 parts conc. HCl and 1 part conc.  $\text{HNO}_3$ ) to ensure proper adherence of the platinum black coating. Please use the fume cupboard and take the necessary protective measures (safety glasses, lab coat and gloves).

Afterwards rinse well with distilled water.

Old platinum black coatings can also be removed with aqua regia.

***Coating***

Connect the electrode to the negative pole as shown in the diagram. Connect another Pt electrode to the positive pole as auxiliary electrode. Slowly increase the current by reducing the variable resistance until the electrode being coated begins to blacken and a slight gas evolution becomes visible (the actual current depends on the electrode surface or on the cell constant of the conductivity measuring cell). After about 5 min, by which time the coating should be a deep black color, switch off the current. When platinizing conductivity measuring cells, reverse the polarity a few times so that both electrodes will blacken evenly.

Afterwards rinse well with distilled water.

---

***Post-treatment***

Finally, electrolyze in a 2% solution of ultrapure sulfuric acid, using the same procedure as for the platinization. Adjust the current with the variable resistance so that a strong gas evolution occurs. With conductivity measuring cells, reverse the polarity a few times. Rinse well with distilled water and leave immersed in water overnight.